

ALLEN COUNTY
Sanitary Engineering Department
204 N. Main Street, Suite 301, Lima, OH 45801

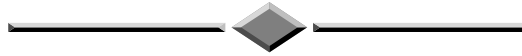

**RULES, REGULATIONS, PROCEDURES AND
GENERAL SPECIFICATIONS
GOVERNING WASTEWATER TREATMENT
AND COLLECTION**

The following Procedures and Criteria are for the information and use of Developers, their Engineers and others in planning and designing sanitary sewers and wastewater treatment facilities in Allen County, Ohio. These Procedures and Criteria are established under authority of Section 6117 and 6103 of the Ohio Revised Code.

Accepted by the Board of County Commissioners on

BOARD OF COUNTY COMMISSIONERS

Dan Reiff

Sam Bassitt

Greg Sneary

Revised 10-01-09

Stephen M. Kayatin, P. E.
Sanitary Engineer

TABLE OF CONTENTS

		PAGE(S)
1.0	Protection of County Sanitary Sewerage Systems	1-6
	1.1 Purpose	
	1.2 Authority	
	1.3 Interpretation	
	1.4 References	
	1.5 Definitions	
2.0	Summary of Procedures in the Construction of Sanitary Sewerage Systems	6-10
	2.1 Assessment Sanitary Sewerage Projects	
	2.2 Non-Assessment Sanitary Sewer Projects	
	2.3 Residential Subdivision Temporary Sanitary Sewerage Systems	
3.0	Approval of Plans	10-15
	3.1 Drawing Contents	
	3.2 Improvements Within or Without Dedicated Streets	
	3.3 Classification of Sanitary Sewerage Improvements and Data to be Submitted	
	3.4 Copies, Reports, and Letters to be Submitted for Approval	
	3.5 Deposit for Plan Review	
	3.6 Ohio Environmental Protection Agency Requirements	
	3.7 Authorization to Construct	
4.0	General Construction, Design Requirements and Specifications of Sanitary Sewerage	15-22
	4.1 Plan Approvals vs. Construction	
	4.2 Approval of Changes or Modifications Made to Plans	
	4.3 Road Opening Permits	
	4.4 Conformance with Allen County Sanitary Engineer's Specifications	
	4.5 Presence of Inspector During Construction of Sanitary Sewer	
	4.6 Improper Construction	
	4.7 Location of Appurtenances	
	4.8 Sanitary Sewer Connections	
	4.9 As-Built Drawings	
	4.10 Private Sanitary Sewerage Facilities being turned over to County Operation	
	4.11 Owner's Responsibility Concerning Engineering Services	
	4.12 County's Responsibility for Information	
	4.13 Protection of Existing Structures	
	4.14 Approval of All Materials and Workmanship	
	4.15 Requirements for Sanitary Sewer Mains	
	4.16 Extension Limits of Sanitary Sewer Mains	
	4.17 Construction of Sanitary Sewers	
		PAGE(S)
5.0	Sanitary Sewer Service Connections	22-26

	5.1	Sewer Connections Required	
	5.2	Necessity of Sewer Permit	
	5.3	Permits on the Job	
	5.4	Inspection of Connection	
	5.5	Materials and Workmanship	
	5.6	Approved Uses of Sanitary Sewers	
	5.7	Non-Approved Uses of Sanitary Sewers	
	5.8	Septic Tank Jurisdiction	
	5.9	Road Opening Permit	
	5.10	Refusal by Sewer Builder	
	5.11	Restoration of Paving and Sidewalks	
	5.12	House Connection Construction with Sanitary Sewer Main Construction	
	5.13	Connection to Temporary Sanitary Sewer	
	5.14	Separate Connection for Each Building	
	5.15	Sanitary Engineer Authority with Regards to Materials	
	5.16	Pipe Installation, Size, Slope	
	5.17	Trench Backfill	
	5.18	Right of Property Access	
	5.19	Notice of Construction	
	5.20	Protection of Structures	
	5.21	County's Maintenance Responsibilities	
	5.22	Connection to Approved Interior Plumbing	
	5.23	Use of Adapters	
6.0		Industrial and Damaging Wastes	26-27
	6.1	Non-Approved Wastes	
	6.2	Furnishing of Chemical Analysis	
	6.3	Pre-Treatment of Waste	
	6.4	Permit Fee Calculation	
	6.5	Monthly Reports	
	6.6	Additional Charges to Quarterly Sewer Bills	
	6.7	Prevention for Accidental Discharges	
	6.8	Sewer User Responsibilities	
7.0		Use of Public Sewers	27-28
	7.1	Discharge of Storm and "Clean" Waters	
	7.2	Discharge from Basements and Foundation Excavations	
	7.3	Prohibited Discharge	
			PAGE(S)
8.0		Protection from Damage	28
	8.1	Damage to Systems	
9.0		Sanitary Sewer Service Charge and Capital Permit Fee (CPF) Billing Procedure and Information	28-29
	9.1	Authority for and Purpose Behind Sanitary Sewer Charges	

	9.2	Quarterly Billing	
	9.3	Delinquent Charges	
	9.4	Delinquent Charges Certified to Property Owners Taxes	
	9.5	Change of Address for Mailing Purposes	
	9.6	Payment of Bills	
	9.7	Capital Permit Fee	
10.0		Violations	29-30
	10.1	Violation of Rules	
11.0		Possible Invalidities and other Agreements	30
	11.1	Invalidities and Agreements	

LIST OF APPENDICES

<u>Appendix</u>	<u>Title</u>	PAGE(S)
A	General Notes	31
B	General Details	32-33
C	Tap Connection Procedures and Requirements	34-35
D	Plan and Profile Detail	36

LIST OF REVISIONS

10-01-09	Added Capital Permit Fee Language and Installment Payments.

1.0 Protection of County Sanitary Sewerage Systems

1.1 Purpose

The rules and regulations contained herein are adopted to provide a well-planned and uniform sanitary sewage system in Allen County, Ohio, in order to preserve and promote the general health and welfare of the public.

1.2 Authority

The Board of County Commissioners, Allen County, Ohio, are authorized to adopt rules and regulations for the construction, maintenance, protection and use of sewers and sewer improvements as provided in Chapter 6117.01 of the Ohio Revised Code.

1.3 Interpretation

The provisions of these regulations shall be held to be minimum requirements. Whenever these provisions are different from the requirements of other lawfully adopted regulations the more restrictive rule or higher standard shall prevail.

1.4 References

1.4.1. City of Lima, Ohio's Standards and Specifications

1.4.2. Water supply, sewerage, and sewage treatment for public buildings in Ohio.

1.4.3. Recommended standards for sewage works, dated May 10, 1960, (ten states standards).

1.4.4. Allen County Subdivision Regulations.(Updated)

1.4.5 Chapter 6117.01 of the Ohio Revised Code

1.5 Definitions

1.5.1 **Biochemical Oxygen Demand** - (BOD) shall mean the quantity of oxygen utilized in the biochemical oxidation of organic matter under standard laboratory procedure, as prescribed in "Standard Methods", in five days at 20 degrees Celsius, expressed in milligrams per liter (mg./l.).

1.5.2 **Building sewer**- that part of the sanitary system, which connects the plumbing of the house or building to a common or public sewer. The building sewer begins three feet from the foundation wall.

1.5.3 **Compatible Pollutants** - Pollutants that the treatment plant was designed to treat which are BOD, SS, and Fecal Coliform bacteria, plus additional pollutants identified in the NPDES Permit if the publicly owned treatment works were designed to treat such pollutants and in fact does remove such pollutants to a substantial degree.

- 1.5.4 **Contractor** -shall mean any person undertaking a contract under these Rules and Regulations acting directly or through a duly qualified and authorized representative.
- 1.5.5 **County** - shall mean Allen County, Ohio.
- 1.5.6 **County Commissioners** - shall mean board of County Commissioners of Allen County.
- 1.5.7 **County Engineer** - shall mean the County Engineer of Allen County, Ohio.
- 1.5.8. **Domestic sewage** - sewage derived principally from dwellings, business buildings, institutions and the like, which originates within the building, including the waste from kitchens, water closets, lavatories, bathrooms, showers and laundries.
- 1.5.9 **Easement** - shall mean an acquired legal right for the specific use of land owned by others.
- 1.5.10 **Foundation Drains** - Subsurface drains lay around the foundation of a building, either within or outside of the building foundation for the purpose of carrying ground or subsurface water to some point of disposal.
- 1.5.11. **Industrial sewage** - the liquid waste from industrial processes as distinct from domestic sewage.
- 1.5.12 **Industrial User** - shall mean, for the purpose of industrial cost recovery:
- I) Any nongovernment, nonresidential or noncommercial user of the treatment works which discharges to the sanitary sewer.
- In determining the amount of a user's discharge for the purposes of high strength surcharges, the County may exclude domestic wastes or discharges from sanitary conveniences.
- II) Any user of the treatment works that discharges wastewater to the treatment works which contains toxic pollutants or poisonous solids, liquid, or gases in sufficient quantity either singly or by interaction with other wastes, to contaminate the sludge of any County systems, or to injure or to interfere with any sewage treatment process, or which constitutes a hazard to humans or animals, creates a public nuisance, or creates any hazard in or has an adverse effect on the waters receiving any discharge from the treatment works.
- 1.5.13 **Industrial Waste** - shall mean the wastewater from industrial processes, trade, or business as distinct from domestic or sanitary wastes.
- 1.5.14 **Infiltration** - shall mean water other than wastewater that enters a sewer system (including building drains and building sewers) from the ground

through such means as defective pipes, pipe joints, connections, or manholes, downspouts, groundwater drains, foundation drains, infiltration does not include, and is distinguished from, inflow.

- 1.5.15 **Infiltration/Inflow** - shall mean the total quantity of water from both infiltration and inflow without distinguishing the source.
- 1.5.16 **Inflow** - shall mean water other than wastewater the enters sewer system (including building drains and building sewers) from sources such as roof leaders, cellar drains, yard drains, area drains, foundation drains, drains from springs and swampy areas, manhole covers, cross connections between storm sewers and sanitary sewers, catch basins, cooling towers, storm waters, surface run-off, street wash waters, or drainage, inflow does not include, and is distinguished from, infiltration.
- 1.5.17 **Inspector** - shall mean a duly appointed representative of the County who is responsible for the enforcement of the specifications and quality of construction.
- 1.5.18 **Nonindustrial User** - shall mean users of the wastewater facilities not classified as an industrial user.
- 1.5.19 **Normal Domestic Wastes** - shall mean wastes which are characterized by a per capita discharge of 75 gal/day at a loading of 240 mg/l BOD and 200 mg/l SS (normal domestic sewage).
- 1.5.20 **NPDES Permit** - shall mean National Pollutant Discharge Elimination System as issued by the State of Ohio Environmental Protection Agency under authorization issued by the U.S. EPA. Region V.
- 1.5.21 **ODOT** - shall mean Ohio Department of Transportation
- 1.5.22 **Operation, Maintenance, and Replacement Costs** - shall mean labor, materials, supplies, equipment accessories, and appurtenances costs required to operate the facilities, keep the facilities in operating condition, and maintain the capacity and performance during the service life of the treatment works for which such works were designed and constructed.
- 1.5.23 **Owner** - shall mean any person, individual, firm, company, association, society, corporation, group or political subdivision that is the legal owner of the real estate involved.
- 1.5.24 **Person** - shall mean the state, any municipal corporation, political subdivision of the state, person as defined in Section 1.59 of the Revised Code, or interstate body created by compact.
- 1.5.25 **PH** - shall mean the logarithm of the reciprocal of hydrogen ion concentration. The concentration of hydrogen ions is expressed in moles per liter of solution.

- 1.5.26 **Public Sewer** - shall mean a common sewer subject to the jurisdiction of the County Commissioners.
- 1.5.27 **Sanitary Engineer** - shall mean the appointed representative of the County Commissioners in the Allen County Sanitary Engineering Department who is a registered professional engineer.
- 1.5.28 **Sanitary Sewer** - a pipe or conduit designed for the purpose of carrying domestic and industrial sewage from the point of origin to sewage treatment or disposal works or to a place of disposal, but which is not intended to carry storm, surface, ground, or subsurface water.
- 1.5.29 **Segregated Domestic Wastes** - are discharges from nonresidential sources generated from normal human biological activities, separate and distinct from industrial trade or process discharges.
- 1.5.30. **Sewage** - the liquid or water carried waste from residences, business building, and institutions together with those from industrial establishments.
- 1.5.31 **Shall** - is mandatory.
- 1.5.32 **Standard Methods** - shall mean the most recent edition of Standard methods for the Examination of Water and Wastewater published by the American Public Health Association.
- 1.5.33. **Storm Sewer** - a pipe or conduit designed for the purpose of carrying storm, surface, cooling and drainage water from the point of origin to some point of disposal, but which is not intended to carry domestic or industrial sewage.
- 1.5.34 **Suspended Solids** - shall mean total suspended matter that either floats on the surface of, or is in suspension in, water, wastewater, or other liquids, and that is removable by laboratory filtering as prescribed in "Standard Methods" and referred to as filterable residue.
- 1.5.35 **Treatment Works** - shall mean any and all devices and systems used in the storage, treatment, recycling, and reclamation of domestic or industrial wastes of a liquid nature, or necessary to recycle or reuse water at the most economical cost over the useful life of the works, including interceptor sewers, outfall sewers, sewage collection systems, pumping, power, and other equipment and their appurtenances; extensions, improvements, remodeling, additions, and alterations thereof; elements essential to provide a reliable recycled supply such as stand-by treatment units and clear well facilities; and any works, including site acquisition of the land that will be an integral part of the treatment process or is used for ultimate disposal of residues resulting from such treatments; or any other method or system for preventing, abating, reducing, storing, treating, separating, or disposing of wastewater, including storm water runoff, or industrial waste, including waste in combined storm water and sanitary sewer systems.

- 1.5.36 **Unpolluted Water** - is water of quality equal to or better than the effluent criteria in effect or water that would not cause violation of receiving water quality standards and would not be benefited by discharge to the treatment works provided. It shall contain not more than 300 mg/1 of dissolved solids, and not more than 90 mg/1 of suspended solids and 45 mg/1 of biochemical oxygen demand.
- 1.5.37 **User** - shall mean those premises connected or required to be connected to the public sewer system.
- 1.5.38 **User Charge** - shall mean that amount paid by each premise connected to the treatment works proportionate to the service provided. This charge shall cover all operations, maintenance and replacement costs for the treatment works.
- 1.5.39 **Wastewater** - shall mean the spent water of a community or segment of a community, from the standpoint of source, it may be a combination of the liquid and water-carried wastes from residences, commercial buildings, industrial plants, and institutions, together with any ground water, surface water, and storm water that may be present.

2.0 Summary of Procedures in the Construction of Sanitary Sewerage Improvements

2.1 Assessment Sanitary Sewerage Projects

- 2.1.1 A resolution by the Board of County Commissioners establishing a sewer district.
- 2.1.2 Preparation of a general plan of sanitary sewerage for the sewer district and approval of it by the Board of County Commissioners and Ohio Environmental Protection Agency.
- 2.1.3 Receipt by the Board of County Commissioners of a petition from affected property owners or a request from the Township Trustees, Allen County Department of Health, or Environmental Protection Agency for a sanitary sewerage improvement.
- 2.1.4 Preparation of detailed plans, specifications, cost estimates and tentative assessments for each improvement by County Sanitary Engineer.
- 2.1.5 Approval of the detailed plans, specifications, cost estimates, and tentative assessments by the Board of County Commissioners, by the municipality, (if within one), County Health Department, and the Ohio Environmental Protection Agency.
- 2.1.6 Passage and publication of a resolution of necessity by the Board of County Commissioners and notification of each property owner affected by the project and Clerk of Council of Municipality (if the project is within one) of the hearing.
- 2.1.7 The Board of County Commissioners conducts a public hearing for all property owners who will be assessed or affected by the proposed

improvement and hears endorsements and objections to the proposed improvement. The Board of County Commissioners also receives letters for five days after the hearing from such property owners that state endorsements or objections to the proposed improvement.

- 2.1.8 Passage of a resolution to proceed with the improvement the Board of County Commissioners not sooner than five days after the public hearing.
 - 2.1.9 Resolution to advertise for construction bids in a newspaper of general circulation in the County not sooner than ten (10) days after passage of the resolution to proceed.
 - 2.1.10 Receipt of construction bids by the Board of County Commissioners and tabulation of such bids by County Sanitary Engineer.
 - 2.1.11 Issuance of notes to finance the improvement by the Board of County Commissioners.
 - 2.1.12 Award of the construction contract by the Board of County Commissioners to the lowest and best bidder.
 - 2.1.13 Construction of the project.
 - 2.1.14 Computation of the final cost of the project and revision of the tentative assessments in the same ratio as the final cost is to the Engineer's estimated cost. **(In no case can the final costs or assessments exceed the estimated costs or tentative assessments at the time of the public hearing).**
 - 2.1.15 Each property owner may pay his assessment interest free in cash during a 30-day period allowed by law following the Board of County Commissioners approval of said assessments. Immediately after the approval of said assessment a notice is mailed to each property owner stating the amount of his final assessment.
 - 2.1.16 Issuance of bonds and redemption of notes by the Board of County Commissioners.
 - 2.1.17 Computation of final unpaid assessments including bond interest.
 - 2.1.18 Approval of final unpaid assessments as certified by the County Sanitary Engineer including bond interest by the Board of County Commissioners and certification to the County Auditor for placing on the tax duplicate for collection.
- 2.2 Non-Assessment Sanitary Sewer Projects for Subdivision Development or Capital Improvement. Procedure in the Construction of Main Sanitary Sewers to Connect to an Existing Sanitary Sewerage:
- 2.2.1 Consultation by the Developer or Owner with the County Sanitary Engineer as to general requirements.

- 2.2.2 The Developer of Owner should furnish three copies of the detailed plans, specifications and estimates of cost as prepared by a Professional Engineer licensed in the State of Ohio for the project.
- 2.2.3 Review and approval of all plans and specifications by County Sanitary Engineer, Municipality or Township Trustees (if located within one), Board of Commissioners, Ohio Environmental Protection Agency, and County Health Department (if a sanitary sewerage improvement). The County Sanitary Engineer will not approve plans for facilities in residential subdivisions until preliminary approval of the plat of said subdivisions has been given by the appropriate Planning Commission.
- 2.2.4 At the time of submission of the detailed plans and specifications to the County Sanitary Engineer, the Owner's Engineer shall also submit in triplicate shop drawings, including pre-cast manhole and manhole step and casting details and information.
- 2.2.5 Submission of one hundred percent performance bond or other satisfactory guarantee and necessary easements by the Developer or Owner to the County when plans are submitted.
- 2.2.6 Construction of the project by a reputable and experienced contractor.
- 2.2.7 Submission of three sets of "As built" drawings to the County Sanitary Engineer by the Owner's Engineer prior to acceptance of the project by the Board of County Commissioners.
- 2.2.8 Acceptance of the project by the Board of County Commissioners for operation by the County Sanitary Engineer.
- 2.3 Construction of Commercial and Residential Subdivision Developments using Package WWTP and supporting collection systems.
 - 2.3.1 The Developer should consult with the County Health Department and the County Sanitary Engineer as to the possible methods of sewage disposal for his proposed subdivision.
 - 2.3.2 If a package wastewater treatment plant is to be constructed, the Developer should obtain the services of a Professional Engineer experienced in wastewater plant design and licensed to practice in the State of Ohio.
 - 2.3.3 The Developer and his Engineer should submit in quadruplicate for the use and/or approval of the Ohio Environmental Protection Agency, County Health Department, the County Sanitary Engineer and the Municipal Engineer (if within a Municipality) a preliminary plan of wastewater disposal for the proposed subdivision.
 - 2.3.4 An examination of the proposed plant site shall be made by the Developer and his Engineer, the Ohio Environmental Protection Agency, the County Health Department, the County Sanitary Engineer, and the Municipal Engineer (if within a Municipality).

- 2.3.5 The Developer shall obtain written permission to discharge the plant effluent into a drainage course or storm sewer from the authority concerned with the maintenance of said drainage course or storm sewer prior to the submission of the detailed plans and specifications.
- 2.3.6 The Developer shall enter into an Agreement with County Health Department prior to applying for building permits.
- 2.3.7 The Developer shall enter into an Agreement with the Board of County Commissioners, which shall oversee the design, construction and operation of the proposed wastewater treatment plant as approved by the County Sanitary Engineer.
- 2.3.8 Prior to the approval of the detailed plans and specifications, the Developer shall submit all deeds, easements, bonds, and deposits as stated in the Agreement with the Board of County Commissioners.
- 2.3.9 The Developer and his Engineer shall submit five satisfactory copies of the detailed plans, specifications and estimates of cost for approval to the Municipality (if located within one) or Township Trustees, the County Health Department, the County Sanitary Engineer, the Board of County Commissioners, and the Ohio Environmental Protection agency.
- 2.3.10 At the time of submission of the detailed plans specifications to the County Sanitary Engineer, the Developer's Engineer shall submit in triplicate to the County Sanitary Engineer detailed shop drawings, catalog data, performance curves, etc. for his approval.
- 2.3.11 **NO CONSTRUCTION IS TO COMMENCE UNTIL THE DETAILED PLANS, SPECIFICATIONS AND SHOP DRAWINGS ARE APPROVED AND ALL REQUIRED PERMITS FROM PUBLIC AGENCIES HAVE BEEN OBTAINED.** Upon approval of the detailed plans, specifications and shop drawings, construction may commence under the continuous daily inspection of the Developer's Engineer or the County Sanitary Engineer. The Developer shall obtain necessary building permits, road-opening permits, and any other permits necessary for the contemplated work prior to the start of construction.
- 2.3.12 The wastewater disposal plant and sanitary sewers shall be accepted for operation and maintenance only after construction is completed to the satisfaction of the Environmental Protection Agency, the County Health Department, and the County Sanitary Engineer. All necessary final documents must be submitted and approved by the Board of County Commissioners, including three sets of "As built" drawings as prepared by the Developer's Engineer and payment of all engineering and inspection costs incurred by the County Sanitary Engineer.
- 2.3.13 A sewer permit shall be obtained from the County Sanitary Engineer for the connection of each house to the sanitary sewer main upon the acceptance of the wastewater disposal plant and sanitary sewers by the Board of County Commissioners.

3.0 Approval of Plans

3.1 Drawing Contents

- 3.1.1 Preliminary - The Developer's Engineer shall submit three (3) copies of the preliminary drawings to the Sanitary Engineer as specified in the Development Procedures. The preliminary drawings shall have a sheet size of 24" X 36" and shall be drawn scale of not less than one inch equals one hundred feet (1"=100)'.

The preliminary drawings shall show the name of the Sewer District, improvement number, Subdivision name, Owner or Developer, the Registered Engineer preparing the drawings, lot layout, location of existing and proposed facilities, general features, and existing and proposed contours to the following intervals:

5 feet where the slope is greater than 10%

1 foot where the slope is less than 10%

- 3.1.2 Detailed Construction - The Developer's Engineer shall submit three (3) copies of the detailed construction drawings together with design computations and supporting data to the Sanitary Engineer.

Each sheet shall have a title block of 6" x 3" in the upper right hand corner showing the Sewer District number, improvement number, plant name, section, Engineer's name and seal, signature, sheet number, number of sheets, and scale. Each sheet shall have a revision block 2" x 3" directly left of the title block. The scale shall be represented graphically directly left of the revision block and shall be 1" = 50' horizontal and 1" = 5' vertical. Each sheet shall have a North arrow.

A cover sheet is required containing a vicinity map, signature block, and sheet reference numbers. The signature block shall include spaces for the Board of County Commissioners, County Sanitary Engineer, County Engineer (when project involves a road right-of-way), and political entities if applicable.

The size, location, dimensions, and elevations of all existing structures in the streets and easements shall be shown on both the drawings and profile. This includes gas mains, electric and telephone poles and conduits, storm sewers, waterlines, sewer lines, streetlights, catch basins, manholes, and all other structures above or below ground, which may affect construction.

The construction drawings shall show property lines, corporation lines, section lines, and other boundary lines, subdivisions indicating plat book page and lot numbers, private driveways, lanes and easements with correct dimensions using dashed lines, bench marks with location, description, and elevations conforming to the U.S.G.S. datum.

Proposed water and/or sewer lines shall be shown as dark solid lines. The profiles of the water and/or sewer lines shall be shown as solid dark

lines. The profiles of the water and/or sewer lines shall be shown on the same sheet as the plan.

The type of materials, joints, and strength shall be shown on the construction drawings using ASTM or AWWA nomenclature. Each set of construction drawings shall contain the following notes as outlined in Appendix A.:

The approval of the detailed construction drawings is valid for six (6) months from the date of the County Sanitary Engineer's signature of approval. If construction has not started at the end of the six (6) month period, the construction drawings must be resubmitted for approval.

- 3.1.3 Record Drawings - The Developer's Engineer shall submit to the Sanitary Engineer as built information and changes during construction on the original drawings. All manholes, risers, valves, fire hydrants, and similar structures shall be located with a minimum of two (2) measurement in feet and tenths of a foot, shall be on the horizontal, and shall not exceed one hundred (100) feet in length. Distances between valves within an intersection shall be shown.

Objects that will be acceptable for reference on the as built drawings are fire hydrants, curbs (perpendicular distance), manholes, utility poles (give description and number), house corner (give house number), corner of concrete drive (give house number), and trees (with spikes).

One set of the record drawings shall be submitted to the Sanitary Engineering Department for review. Upon notification by the Sanitary Engineer of approval, the Developer's Engineer shall furnish the Sanitary Engineering Department two (2) sets of permanent reproducible tracings and two (2) sets of the record drawings. See Appendix D for Typical "As Built" Plan and Profile Sheet

- 3.2 Plans for proposed sanitary sewerage improvements which are proposed for construction in Allen County, Ohio, outside of any municipal corporation, inside of any municipality with the municipality's consent to the County's acting on behalf of the municipality, or within or connecting or proposed to connect to any County operated sewer district or system, shall be prepared by a Professional Engineer licensed to practice in the State of Ohio, who is experienced in such work and shall be submitted to the Allen County Sanitary Engineer (hereinafter called the Sanitary Engineer) for approval. Said plans shall then be submitted to the Board of County Commissioners (hereinafter called the Commissioners), to the Ohio Environmental Protection Agency and to other agencies and authorities as contained in Chapter II "procedures" for approval prior to the installation of the improvements. Plans for the following classes of improvements must be submitted for approval, whether proposal for construction within or without any County sewer district previously established by the Commissioners.

Class A:

Proposed public sanitary sewerage including treatment plants, sanitary sewage conveyance systems and any changes in existing structures or methods of treatment for unincorporated communities, or other lands outside of municipal

corporations or connecting with any County system. A Public Sanitary Sewerage System shall be construed to mean a system serving three or more dwellings or buildings as described above, except for that sanitary sewerage which is constructed on public lands, in public highways, dedicated roadways, streets or alleys, or in easements which serve less than three dwellings or buildings as above described, but which may, in the opinion of the Sanitary Engineer, be made to serve additional dwellings or buildings, existing or proposed, along its line, or which may be extended to serve additional dwellings or buildings.

Class B:

Proposed sanitary sewerage including treatment or supply facilities of industrial or commercial establishments which discharge their wastes into a sanitary sewerage system operated and maintained by the County of Allen, Ohio, or which is under lease or franchise from said County.

For the purposes of these regulations, an industrial establishment shall be one engaged in the manufacture of a product, and a commercial establishment shall be one, which is engaged in selling goods or services to either a public or a private clientele.

- 3.3 Proposed sanitary sewerage improvements of the classifications described in Section 1 of this Chapter may be constructed in Allen County (hereinafter called the County) outside of any municipal corporation or inside of any municipality with the municipality's consent to the County's acting on behalf of the municipality subject to the following regulations:

Case 1:

Within established sewer district on undedicated thoroughfares or private rights-of-way.

If the improvement is proposed for construction on an undedicated thoroughfare or private right-of-way, and is to be operated by the Commissioners, the Owner shall agree to dedicate the thoroughfare or furnish a right-of-way deed for the private right-of-way. For this purpose he shall furnish to the County, before he shall be given a permit for the construction work, a bond, acceptable to the Commissioners, in an amount fixed by said Board, but not less than one thousand dollars (\$1,000.00) to insure the dedication of such thoroughfare or the furnishing of such right-of-way deed, within a time prescribed by the Commissioners, and free and clear of all encumbrances, and also to insure the grading, draining, and other improvements as prescribed by these or other rules and regulations of the Commissioners. Such improvements shall be designed by, and the construction of such improvements shall be under the general supervision of a Professional Engineer licensed in the State of Ohio, experienced in the design and construction of sanitary sewerage facilities.

Case 2:

Within a sewer district on a dedicated thoroughfare.

If the improvement is proposed for construction within an established County sewer district, on a dedicated and accepted thoroughfare or right-of-way, the improvement shall be designed by and the construction of such improvements shall be under the supervision of a Professional Engineer, registered in the State of Ohio, and experienced in the design and construction of sanitary sewerage facilities, and constructed under the provisions of the Commissioners, and County Sewer District Law (Section 6117.01 et seq. of the Ohio Revised Code).

3.4 Three copies of satisfactory detailed plans, specifications, cost estimates, detailed shop drawings, catalog data, and pump performance curves, etc. for all improvements provided for under Section 1 and 2 of this Chapter shall be submitted to the Sanitary Engineer, and shall be accompanied by (1) a report prepared by the design engineer, giving all pertinent data regarding the project, and (2) a communication addressed to the Commissioners referring to the plans and specifications and requesting their approval of the same. The Owner shall sign such a communication.

3.4.1 All plans and specifications, which are improperly prepared or accompanied by insufficient or inaccurate information, may be rejected by the Sanitary Engineer, whereupon, revised plans and specifications or more sufficient data shall be submitted, as required. Construction of the improvement will not be authorized until satisfactory engineering plans and data have been submitted to and approved by all of the approving authorities.

3.5 At the time of submission of the plans and specifications, there shall be deposited with the Sanitary Engineer, an amount of money, as estimated by the Sanitary Engineer, sufficient to cover the cost of examining such plans and the accompanying data, including any field investigations and inspections in connection therewith, including inspection of construction.

3.6 The submission to and approval of plans and specifications for sanitary sewerage improvements by the Commissioners will not relieve the Owner from requirements of the Ohio Environmental Protection Agency with reference to the approval of plans and specifications for certain improvements.

3.7 The authorization to construct any sanitary sewerage improvement shall be a letter issued to the Owner from the Sanitary Engineer stating that permission to commence with construction has been granted. Such a letter shall not be sent until the approvals of the Commissioners and, where necessary, Ohio Environmental Protection Agency has been secured.

4.0 GENERAL CONSTRUCTION, DESIGN REQUIREMENTS AND SPECIFICATIONS OF SANITARY SEWERAGE IMPROVEMENTS.

4.1 No sanitary sewerage construction included under the classifications of Chapter III shall be started until after the plans have been approved by the Sanitary Engineer, the Commissioners and where necessary, the Ohio Environmental Protection Agency, and authorization has been granted by the Sanitary Engineer, as herein provided. The installation shall be in strict accordance with such approved detailed plans, specifications, and shop drawings, etc. Construction of sanitary sewerage facilities to be operated by the County shall not proceed until detailed shop drawings have been submitted in triplicate and approved by the Sanitary Engineer.

- 4.2 If any change or modification is deemed necessary or desirable by the public officials or persons, firm or corporation having charge of work, previous to or during the construction, such change or modification shall be incorporated in revised plans, which shall be submitted for approval in the same manner as required for original plans.
- 4.3 Before receiving a permit for any work requiring excavation in any street, highway or road right-of-way, the person desiring to make such excavation shall obtain from the proper authority, the required permit for such work, and shall agree to comply with all requirements of the authority issuing such "road opening permit". If the authority having jurisdiction over a particular street or highway requires no "road opening permit", a written statement to that effect must be obtained from the authority.
- 4.4 The material and workmanship must conform in all respects to the requirements of the specifications of the County Sanitary Engineer which specifications shall be considered as minimum specifications and if built by contract, the contract shall contain this stipulation.
- 4.5 No construction work in connection with the improvement shall be done except in the presence of an inspector authorized by the Sanitary Engineer. Forty-eight hours of notice of the intention to begin work shall be given to the Sanitary Engineer to enable him to arrange to place one or more, if needed, inspectors on the work. The Owner's Engineer shall also act as Resident Engineer for the improvement.
- 4.6 If the Sanitary Engineer has proof or evidence that any such work is being improperly done, he may order all work stopped and the Owner or his contractor shall thereupon stop and shall not resume until authorized in writing by the Sanitary Engineer to do so.
- 4.7 Wye-branches, manholes and other sanitary sewer appurtenances shall be placed where required by the Sanitary Engineer.
- 4.8 Connections with sanitary sewers constructed under this article shall be subject to all the requirements of Chapter V of these rules, regulations, procedures and general specifications.
- 4.9 At the completion of the work, a set of "As Built" plans shall be furnished by the Owner.
- 4.10 Sanitary sewerage facilities constructed with the consent of the Commissioners for private operation may, after completion, be turned over to the County by proper legal procedure, accompanied by proper easements or dedication of suitable rights-of-way.
- 4.11 No provision in this article shall be so construed as to relieve the Owner from the responsibility to furnish all private engineering, surveying and inspection services necessary in connection with the improvements.
- 4.12 The County expressly disclaims any responsibility for the accuracy or completeness of information given on drawings, orally or in writing by any of its

employees in regard to existing structures, and the contractor shall have no claim against the County on the account of such information given.

- 4.13 In excavating and backfilling trenches, and constructing sanitary sewerage facilities, care must be taken not to move or injure any structures, and water courses, whether above, at or below the surface of the ground. If necessary, the contractor or the sewer builder in the case of house sanitary sewer connections, shall at his own expense sling, shore up, and secure and maintain in operating condition any such structure or watercourse. If damaged, he shall repair any such damage, and shall maintain them in good repair until the final acceptance of the job.
- 4.14 Approval of the quality of all materials and workmanship by the Sanitary Engineer shall be required. The Sanitary Engineer may require testing of equipment or materials at the place of manufacture by an independent testing laboratory or by others, at no expense to the County.
- 4.15 General minimum specifications applying to sanitary sewer lines, other than house connections, which are discussed in Chapter 5 of these rules and regulations, are as follows:

4.15.1 Material Selection - The materials listed below may be accepted for sanitary sewer construction. However, the design engineer should contact the Sanitary Engineering Department prior to final material selection. The selection of materials should take into account the nature of the wastes to be transported, compatibility with adjacent and connecting materials and the cleaning methods, which will be used.

All sanitary sewer pipe shall be one of the following:

- 4.15.1.1 V.C.P. (ASTM-C-700)- all diameters
- 4.15.1.2 PVC (ASTM-D-3034 SDR 35) - all diameters
- 4.15.1.3 PVC (profile wall gravity sewer pipe)- one-piece seamless extruded (ASTM F-794) joints shall conform to ASTM-C-443-63T and C425 and any changes thereto. - 15" diameter and larger.

4.15.2 The minimum size of sanitary sewer mains shall be eight inches (8") inside diameter.

4.15.3 The slope of the sanitary sewer main shall be determined so as to provide a minimum velocity of two feet (2') per second when the sewer is flowing half-full. The minimum slope per foot shall meet the following table values:

Sewer Size <u>inches</u>	Slope <u>ft/100 ft.</u>	Capacity <u>CFS</u>	Capacity <u>gal/min.</u>
4	1.20	0.180	80
6	0.62	0.393	176
8	0.40	0.698	313
10	0.28	1.09	489
12	0.22	1.57	705
15	0.15	2.45	1,100
18	0.12	3.53	1,585

21	0.10	4.81	2,160
24	0.08	6.28	2,820
27	0.07	7.95	3,570
30	0.06	9.82	4,409
33	0.05	11.88	5,334
36	0.045	14.14	6,349
42	0.037	19.24	8,639
48	0.031	25.13	11,280
54	0.026	31.81	14,280
60	0.023	39.27	17,630

4.15.4 Testing shall consist of air and/or exfiltration tests for sanitary sewer lines and air and/or vacuum tests for manholes. The Sanitary Engineering Department Inspector must be present to witness all testing of sanitary sewers.

4.15.4.1 Testing shall be performed on all of the following:
All pipe - Leakage and deflection test required.

4.15.4.2 Test Inspection - The leakage and deflection tests shall be carried out and certified by a registered Professional Engineer and the results sent to the Sanitary Engineer. Leakage tests and deflection tests are to be run on the entire length of the project.

4.15.4.3 Deflection Test - Deflection tests must be run more less than 30 days after final full backfill has been placed. No pipe shall exceed a deflection of 5%.

4.15.4.4 Leakage Allowance - The maximum allowable leakage inward or outward (infiltration or exfiltration) for any sanitary sewer section tested, including all manholes, is 200 gallons per inch diameter per mile of pipe per day. Manholes may be tested separately. The above allowable leakage rate is equivalent to 0.16 gallons per inch of diameter per 100 feet of pipe per hour.

4.15.4.5 Leakage Test -

Exfiltration Test
Low Pressure Air Test

4.15.5 The minimum inside diameter of manholes shall be four feet (4') in accordance with the Allen County Standards. Kor-n-seal manhole connections shall be used when connecting into any existing manholes. The appropriate Kor-n-seal details shall be present on all construction drawings. All newly installed sanitary manholes shall have a "No Flow In Flow" manhole dish (ASTM-D-1248) or an acceptable equivalent for prevention of Infiltration and Inflow. All newly installed sanitary manholes shall be constructed with interior chimney seals (ASTM C-923) between dome and casting. Precast concrete manholes shall be constructed so that there will be a maximum of twelve inches of precast concrete rings between the manhole cover

frame and the top precast concrete section. Manhole frames, covers and steps shall be in accordance with Allen County standards. See Appendix B for details.

- 4.15.6 Water Tightness - Manholes shall be constructed to permit grade adjustments by use of cast-in-place or precast concrete adjusting collars not to exceed 12 inches in height. Solid manhole covers should be used in all locations. The manhole casting shall be adjusted so the top of the manhole cover is slightly above grade to prevent the entrance of surface water. All manhole covers, seating frames, and adapter rings shall be machined to a firm and even bearing to provide a true fit into the frames. Inlet and outlet pipes shall be joined to the manhole with a gasketed flexible watertight connection. The type connection specified shall be clearly noted in the specifications and on the detailed drawings.
- 4.15.7 Flow Channel - The invert of the lowest pipe entering a manhole shall be at least three inches above the top of the base slab so that the sewer flow channel may be installed and shaped. The flow channel through manholes should be made to conform in shape, slope and smoothness to maintain the same velocity as that in the sewers. Cut pipe shall not extend beyond the inside face of the manhole wall. Concrete placed inside the manhole to form the channel through the manhole shall not be placed between the pipe and the opening so as to interfere in any way with the flexibility of the joint.
- 4.15.8 Drop Manholes - All drop manholes shall be precast and used when the invert of the inflow sewer is two feet or more above the manhole invert. When this difference in elevation is less than two feet, the manhole invert shall be filleted to prevent solids deposition. Due to the unequal earth pressures that would result from the backfilling operation in the vicinity of the manhole, the entire outside drop connection shall be encased in precast concrete. Drop manholes should be constructed with outside drop connection. Inside drop connections (when necessary) shall be secured to the interior wall of the manhole and provide access for cleaning.
- 4.15.9 Manholes shall not be spaced greater than 400 feet on sanitary sewers.
- 4.15.10 The allowable pipe loading shall be computed by using the maximum trench width - usually the pipe outside diameter plus eighteen inches (O.D. + 18") or 30 inches, whichever is greater - and an "ordinary bedding" condition.
- 4.15.11 All sanitary sewers shall be laid on an angular granular bedding, equivalent to #57 slag or limestone, from four inches below the bottom of the pipe placed to the pipe spring-line and shall have a hand-placed, well-compacted hand-selected backfill in maximum six inch (6") layers to twelve inches (12") above the top of the pipe. All sanitary sewer construction shall be in accordance with the Standards and Specifications of the Sanitary Engineer, which shall be considered as minimum.

4.15.12 Miscellaneous

- 4.15.12.1 Casing - If casing is required, the casing pipe shall be steel pipe of size and thickness acceptable to the County Sanitary Engineering Department and approved by the Ohio E.P.A.
- 4.15.12.2 Encasement - If encasement is required, concrete shall completely surround the pipe and shall have a minimum thickness of one sixth of the inside diameter of the pipe or four (4) inches, whichever is greater. The ultimate compressive strength for the concrete shall be greater than 2500 p.s.i. at 28 days.
- 4.15.12.3 Railroad and Highway Crossings - If casing is required, a casing pipe shall be designed to meet the requirements of the local authority having jurisdiction and in compliance with Item 1 of this Section. The inside diameter of the casing pipe shall be at least four (4) inches greater than the largest outside diameter of the sewer pipe, joints or couplings.
- 4.15.12.4 Stream Crossings - The crown of all sewers crossing the streams shall be at sufficient depth below the natural bottom of the streambed. The minimum cover over the crown of the pipe shall meet one of the following requirements:
- One foot if the sewer is located in rock or the sewer is constructed in accordance with any method as prescribed in Items 4.15.12.1 and 4.15.12.2 of this Section.
- Four feet if the sewer is located in materials other than rock.
- The crossing shall be free from change in grade and the sewer should be designed to cross the stream as nearly perpendicular to the stream flow as possible.
- 4.15.12.5 Sewer Outfall - A sewer outfall structure shall be so located that it does not restrict the free flow in the stream.
- 4.15.12.6 Sewer Above the Ground - If a sewer is constructed above the ground, the sewer should be adequately protected against freezing, and shall be free from leakage. The structure supporting the pipe shall be designed to prevent frost heave, overturning and settlement.
- 4.15.12.7 Inverted Siphons - Inverted siphons should have at least two barrels, with a minimum pipe size of six (6) inches. Manholes shall be designed to provide sufficient room for rodding, flushing, and other maintenance. Sufficient head shall be provided and pipe sizes selected to obtain velocities of at least 3.0 feet per second for average flow. The inlet and outlet details shall be arranged so that the normal flow is diverted to one barrel, and so that either barrel may be out of service for cleaning.

4.15.12.8 Pump Stations and Telemetry

- 4.16 All sanitary sewer mains shall be extended along dedicated road rights-of-way to the limits of the property being served by those utilities. It may be required that sanitary sewers mains that are located within easements, also be extended to the limits of the property being served by those utilities.
- 4.17 Water mains and main sanitary sewers are to be constructed on opposite sides of traveled ways or pavements within easements and dedicated roads right-of-ways. In instances, where this is a physical impossibility, a minimum of ten (10) feet shall be maintained between water mains and main sanitary sewers. The construction of sewers in easements at the rear or side of residential lots shall be prohibited except as approved by the County Sanitary Engineer.

5.0 SANITARY SEWER SERVICE CONNECTIONS

- 5.1 No sewage disposal device or equipment shall be installed on property accessible to an improved public sanitary sewerage system. No sewage disposal device or equipment shall be used on property, which is accessible or becomes accessible to an improved public sanitary sewerage system. Whenever an improved sanitary sewerage system is made available, property owners fronting the sewerage system will be given sixty (60) days to connect to the new public sewerage system following completion of the system. Said connection shall be so ordered by the Sanitary Engineer. Any abandoned sewage tank or other device or equipment used for treatment or disposal of sewage shall be thoroughly cleaned, broken up, and filled to the ground surface with a suitable filling material as approved by the Public Health Department.
- 5.2 No new connection, repair, removal, or any excavation shall be made to any sanitary sewers without a permit from the Sanitary Engineer. A fee will be charged for all permits based on Allen County Suggested Water Usage Guidelines. The Board of County Commissioners may change this fee as necessary. See also Industrial Permits, Section 6.5. The County shall make all taps into mainline sewers with its tapping machine. The Allen County Sanitary Engineering Department shall furnish and install all saddles onto the mainline sewer. In accordance to all Federal, State, and County safety standards.
- 5.3 Permits shall be kept and made visible on the job at all times while the work is in progress.
- 5.4 All work shall be inspected by an inspector representing the Sanitary Engineer. Contractors shall notify the Allen County Sanitary Engineering Department 24 hours in advance of the date and time at which construction of the sanitary sewer lateral will begin. The inspector from the Allen County Sanitary Engineering Department shall be present at all times of the testing process or in the absence of the inspector a representative from the engineering firm shall be present as arranged by the inspector. The Contractor shall uncover any work covered previous to the inspection and an opportunity must be given to inspect the inside as well as the outside of the sewer pipe. All materials and workmanship shall be in strict accord with the sanitary sewer specifications of the Sanitary Engineer governing such work and the same is hereby made a part of these rules, regulations, procedures, and specifications.

- 5.5 The Sanitary Engineer shall approve the quality of all materials and workmanship, and shall have the right to inspect the site at all times. He may order removed from the job any inferior or defective material, and he may cause any portion of a house connection to be re-laid which is not laid to the Sanitary Engineering Department's satisfaction. The Sanitary Engineer shall have free access to all buildings and fixtures therein connected to the sanitary sewers to inspect such fixtures. The Sanitary Engineer in any duty prescribed by these rules and regulations, may act through properly authorized representatives.
- 5.6 The sanitary sewers shall be used for all water borne wastes from water closets, urinals, lavatories, normal kitchen, bathroom and laundry fixtures, refrigerators, soda fountains, cellar and garage floor drains, or other fixtures which may be designated by the Sanitary Engineer whether from residences, factories, commercial buildings, enterprises, trailers, schools, buildings, and for no other purpose except by special written permission of the Sanitary Engineer. Wastes from the above sources shall hereinafter be called "sanitary wastes". No such sanitary wastes shall be allowed to enter any storm sewer, storm ditch, watercourse, stream or pond. No wastes which are likely to cause damage or stoppage of sanitary sewers or which may interfere with the treatment thereof will be permitted to enter a sanitary sewer.
- 5.7 In no case may storm, surface or ground water, or water from drain spouts, roofs, cisterns, yard drains, subsoil drains, footer drains, foundations drains, or waste material from water motors, cooling water, or excessively hot waters be allowed to enter a sanitary sewer except with the written permission of the Sanitary Engineer.
- 5.8 Vaults, cesspools, and septic tanks serving homes shall be subject to the rules and regulations of the Ohio Environmental Protection Agency and/or Allen County Health Department.
- 5.9 Before receiving a permit for any work requiring excavation in any street, highway or road right-of-way, the person desiring to make such excavation shall obtain from the proper authority the required permit for each excavation and shall agree to comply with all the requirements of the issuing authority, or shall obtain a written statement by that authority that no road opening permit is required. This permit shall be shown to the inspector at the commencement of construction and shall be kept "on-the-job" at all times, while work is in progress.
- 5.10 If any Contractor shall neglect or refuse to do anything required by these rules and regulations within a responsible time after receiving written notice from the Sanitary Engineer to do so, the Sanitary Engineer may order such work to be done and charge the cost to the Contractor. The Contractor's diligence in making restoration of damaged property, settled backfill or reseeded for which he is responsible, will be considered in issuing permits to the Contractor.
- 5.11 Any paving, sidewalks, drives, etc. that are damaged or removed during installation of a house drain and need to be repaired within one year after completion will be billed to the owner. The Owner shall upon receiving notification in writing from the Sanitary Engineer of the necessity for such repairs, immediately perform or have performed the work called for in such

notification. Failure by the Owner to complete the work within a period of 96 hours after such notification may cause such work to be done either by contract with some capable person, or by such other arrangements as may be most convenient and satisfactory. The bill for the cost of the repairs shall be rendered to the Owner who shall be liable for and shall pay such bill immediately

- 5.12 Where a connection is to be made a temporary or private sanitary sewer lying within street lines, property owners will be required to sign an agreement or blanks provided for that purpose, that they will make no objection to a permanent sanitary sewer or to the tax assessed for the same.
- 5.13 A separate and individual sanitary sewer connection shall be made for each building. No connection shall serve more than one building unless the Sanitary Engineer gives specific authority.
- 5.14 The Sanitary Engineer shall allow or disallow the use of any material for house connections or sanitary sewer mains, as he shall see fit. The Sanitary Engineer shall have the authority to make a change in materials authorized for use in systems under his jurisdiction at any time.
- 5.15 The sanitary sewer pipe shall be installed so that the barrel will be supported over its full length on: (a) firm, undisturbed earth shaped to the bottom quadrant of the pipe with bell holes to receive bells or couplings with at least one inch of clearance below the bottom of the bell, or (b) on a minimum four inch bedding of well compacted #57 stone excavated material of a granular nature. The sanitary sewer lateral shall be laid so as to be centered in a dry trench of minimum width (30" is usually considered the maximum width) in a straight line with uniform slope. The minimum slope shall be 1/8 inch per foot. The minimum pipe size shall be six inch (6") inside diameter and shall be of the premium joint type.
- 5.16 Hand backfill shall be placed and compacted under and around the pipe in six-inch layers to one foot above the top of pipe. Sand or granular material will not be required for this purpose, but the material used must be free of rocks or stones one or more inches in diameter and be capable of compaction. Frozen, lumpy, saturated, or other non-compactable material will not be accepted. Material for hand backfill should under no circumstances be dumped on the exposed pipe, but should be moved along the trench. The remainder of the trench may be machine backfilled. Backfill entering the trench must come upon previously placed machine backfill. Direct placement of machine backfill on hand backfill will not be allowed. All excavations in paved areas shall be backfilled with well-compacted sand and gravel, or in accordance with the requirements of the road-opening permit, if stricter.
- 5.17 The Sanitary Engineer is granted the right to enter any and all properties, to inspect sewer connections and any appurtenances thereto, to collect samples of wastes, and to test for violations of these rules and regulations.
- 5.18 The presence of the Sanitary Engineer or his authorized inspector does not relieve the Contractor of his duty to protect any structures above, below or at the surface of the ground. Should any damage arise due to the negligence of the sewer builder, it shall be his bonded duty to make right any such damage within a period of 96 hours. If the owner fails to do this, the Sanitary Engineer may

order the damages to be repaired or the damaged property replaced either by contract, with some capable person, without advertising or by other arrangements as may be most convenient and satisfactory. The bill for the entire cost of the work shall be rendered to the Contractor who shall be liable for and shall pay the same at once.

- 5.19 The County will perform all maintenance of the sanitary sewer main. The homeowner will be responsible for the maintenance of the sanitary sewer lateral between the right-of-way and the house. The County may require the property owner to make whatever repairs or perform any maintenance that the County deems necessary for the proper functioning of the sanitary sewerage system. If the County is called upon or finds it necessary to repair or maintain any house connection, the cost of such repair or maintenance shall be billed directly to the homeowner. The County disclaims any responsibility for damages caused by/or arising from any stoppage of the main sanitary sewer.
- 5.20 The connection between the interior plumbing and the sanitary sewer service connection shall be made at a point approximately three feet outside the foundation wall.
- 5.21 Adapters shall be used to connect between dissimilar pipe sizes or joints between (a) lateral and branch of wye in main, (b) house connection and lateral, and (c) cast iron soil pipe and house connection. If adapters are not available, where the soil pipe and house connection pipe are to be connected, adequate concrete encasement will be required.

6.0 INDUSTRIAL AND DAMAGING WASTES

- 6.1 Industrial wastes of a nature, which will cause damage to the sanitary sewerage system, or which will interfere with the treatment processes shall be barred from the sanitary sewerage system. In no case will an industry or commercial establishment be allowed to discharge oils, gasoline's, thinners, any highly volatile substances, any highly acid or basic substances, or any other waste which may tend to damage the sanitary sewerage system or cause a stoppage of the same. The Sanitary Engineer shall have authority to enter any property for the purpose of obtaining samples of waste discharged into the sewers.
- 6.2 An industry must, upon application for sewer service, present to the Sanitary Engineer, a tabulation of the chemical analysis of the waste to be discharged into the sanitary sewerage system and the volume of such waste, or if this is not available, the expected waste analysis based on similar processes now in operation.
- 6.3 The Sanitary Engineer shall, if he finds it necessary, require pretreatment of a waste prior to its discharge into a public sanitary sewerage system.
- 6.4 The permit fee for connecting any industry to a sanitary sewer shall be based on the actual cost plus overhead for reviewing the plans and inspecting the construction of the connection from the main sanitary sewer to the plant buildings and of any pretreatment devices.

- 6.5 A monthly report of the quantity and characteristics of any industrial waste discharged into a sanitary sewer shall be presented to the Sanitary Engineer no later than the 15th day of the following month.
- 6.6 In addition to the minimum charge and volume charge, any user discharging wastewater containing BOD in excess of 200 mg/l (or COD in excess of 500 mg/l) or suspended solids of 250 mg/l shall be subject for surcharges to the regular quarterly sewer bill an additional amount as directed by the Sanitary Engineer and approved by the Board of County commissioners on individual applications of users.
- 6.7 Each industrial user shall provide protection from accidental discharge of prohibited materials or wastes regulated by these Rules and Regulations. The facilities to prevent accidental discharge of prohibited materials shall be borne by the owners of the industrial user facilities.
- 6.8 If, for any reason, a facility does not comply with or will be unable to comply with any prohibition or limitations in these Regulations, the user responsible for such discharge shall immediately notify the County so that corrective action may be taken to protect the treatment system. All costs involved with said corrective action shall be assessed against the property owner.

7.0 USE OF PUBLIC SEWERS

- 7.1 No person, firm or corporation shall discharge or cause to be discharged any storm water, ground water, roof run off, sub-surface drainage, cooling water or unpolluted industrial process water to any sanitary sewer.
- 7.2 It shall be unlawful to discharge into the building sanitary sewer the surface water, which collects in basement or foundation excavations. If the building sanitary sewer is complete before the plumbing can be connected thereto, the builder or sewer tapper shall keep the end of the building sanitary sewer tightly closed with a plumber's plug or other watertight plug.
- 7.3 It shall be unlawful for any person, firm or corporation to discharge or permit the discharge of any of the following described waters or wastes to any public sanitary sewer:
- (a) Any oils, acids, cyanides, explosives or inflammable compounds, industrial chemicals, poisons and any other substances, gas or liquid, which may in any way damage or interfere with the use or operation of the sanitary sewers, or sewage treatment plant in excess of maximum concentration as determined by the Sanitary Engineer or which may create a hazard to life.
 - (b) Any garbage that has not been properly shredded.
 - (c) Any ashes, cinders, sand, mud, straw, shavings, metal, glass, rags, feathers, tar, plastics, wood, paunch manure, or any other solid or viscous substance capable of causing obstruction to the flow in sewers or other interference with the proper operation of the sewage works.

- (d) Any waters or wastes containing suspended solids of such character and quality that unusual attention or expense is required to handle such materials at the sewage treatment plant, or having a chlorine demand greater than 25 p.p.m.

8.0 PROTECTION FROM DAMAGE

- 8.1 No unauthorized person shall maliciously, willfully, or negligently break, damage, destroy, uncover, deface, or tamper with any structure, appurtenances or equipment which is a part of the County sanitary sewerage system. Any person violating this provision shall be subject to immediate prosecution under charge of disorderly conduct.

9.0 SANITARY SEWER SERVICE CHARGE, BILLING PROCEDURE AND INFORMATION

- 9.1 In accordance with Section 6117.02 (A) of the Revised Code the Board of County Commissioners shall fix reasonable rates, including penalties for late payments, for the use, or the availability for use, of the sanitary facilities of a sewer district to be paid by every person and public agency whose premises are served, or capable of being served, by a connection directly or indirectly to those facilities when those facilities are owned or operated by the county and may change the rates from time to time as it considers advisable. When the sanitary facilities to be used by the county are owned by another public agency or person, the schedule of rates to be charged by the public agency or person for the use of the facilities by the county, or the formula or other procedure for their determination, shall be approved by the board at the time it enters into a contract for that use.

The Sanitary Engineer shall regularly review the quarterly sanitary sewer service charge for each individual connection to any and all sanitary sewerage systems operated and maintained by the County Sanitary Engineering Department in County Sewer Districts. The purpose of the sewer service charges is to provide the department for all expenses incurred by it in operating, maintaining and financing of improvements to the sanitary sewerage systems under its jurisdiction.

- 9.2 Quarterly sewer service charges as established by the Board of County Commissioners are normally billed to the owner of any property connected to a County operated sanitary sewerage system. If the owner of any property elects to have his tenant or lessee pay these charges as they accrue, such tenant or lessee does so as the agent of the owner, and such owner shall be held responsible for unpaid charges.
- 9.3 In accordance with 6117.02 (C) when any quarterly sewer service charge is not paid by the final pay date of the particular quarter, a fee is charged of said date and is indicated on the sewer service statement itself, the amount shall be deemed delinquent. When a sewer service charge has become delinquent, a 10% penalty shall be added to the final net pay amount. The County shall not be liable for sewer service statements not delivered by the postal authority due to change of addresses or the postal authority failure to complete their assigned tasks.

- 9.4 Delinquent sewer service charges not paid by the second Monday in September of each year, shall be certified to the County Auditor for collection with the taxes due for a particular property and they shall become a lien against the property. All certifications shall be made at least annually prior to the second Monday in September.
- 9.5 Bills for sewer service charges will be mailed where directed as a matter of convenience to the owner of property or their agents. Failure to receive bills will not relieve anyone of the responsibility for prompt payment. It is the property owner's obligation to notify the County Sanitary Engineer of any change of, or error of address.
- 9.6 Current bills and delinquent bills not certified to the County Auditor for sewer service charges are payable at the office of the County Sanitary Engineer or at any one of several locations specified on the bills themselves.
- 9.7 In accordance with Section 6117.02 (B) of the Revised Code the board also shall establish reasonable charges to be collected for the privilege of connecting to the sanitary facilities of the district, with the requirement that, prior to the connection, the charges shall be paid in full, or, if determined by the board to be equitable in a resolution relating to the payment of the charges, provision considered adequate by the board shall be made for their payment in installments at the times, in the amounts, and with a carrying charge as may be found by the board in that resolution to be fair and appropriate. No public agency or person shall be permitted to connect to those facilities until the charges have been paid in full or provision for their payment in installments has been made.

If the connection charges are to be paid in installments, the board shall certify to the county auditor information sufficient to identify each parcel of property served by a connection and, with respect to each parcel, the total of the charges to be paid in installments, the amount of each installment, and the total number of installments to be paid. The auditor shall record and maintain the information supplied in the sewer improvement record provided for in section 6117.33 of the Revised Code until the connection charges are paid in full. The board may include amounts attributable to connection charges being paid in installments in its billings of rates and charges for the use of sanitary facilities as follows:

- 9.7.1 Installment – The customer shall pay their connection fee over an installment period of five (5) years with a carrying charge to be determined at the time of connection. A residential customer will need to provide proof of meeting the County's low-to-moderate income status, for approval to exercise the installment option prior to connection. Customers with multiple equivalency based connection charge shall exercise the installment option upon providing information to calculate said charge, and verification by the Sanitary Engineer prior to connection.

10.1 Whoever violates Section 6103.29 and/or 6117.45 of the Ohio Revised Code shall be fined in accordance with the Ohio Revised Code.

Whoever violates these rules, regulations, procedures, and general specifications shall be subject to injunction action or other legal actions under the pertinent sections of the Ohio Revised Code.

11.0 POSSIBLE INVALIDITIES AND OTHER AGREEMENTS

11.1 The several parts of the foregoing rules, regulations, procedures, and general specifications are hereby declared separate and in the event any provision or part hereof shall be declared void and ineffective for any cause, such declaration shall not effect nor render invalid any other provision or part hereof.

Nothing in these rules, regulations, procedures and general specifications shall prohibit the Board of County Commissioners or the County Sanitary Engineer from entering into an agreement with any person, firm corporation or governmental agency for the furnishing of a service or performance of any act not specifically mentioned in these rules, regulations, procedures and general specification

APPENDIX A

Sanitary Engineering Department General Notes

1. Sanitary sewers shall be V.C.P. (ASTM-C-700), PVC (ASTM-D-3034 SDR 35), or PVC profile wall gravity sewer pipe - one piece seamless extruded (ASTM F-794) joints shall conform to ASTM-C-443-63T and C425 and any changes thereto.
2. Contractor shall notify the Allen County Sanitary Engineering Department 2 working days in advance of the date at which construction will begin on the sanitary sewers.
3. Contractor shall notify the Allen County Sanitary Engineering Department 2 working days in advance of the date and time at which testing of the sanitary sewers will begin. The inspector from the Allen County Sanitary Engineering Department shall be present at all times of the testing process or in the absence of the inspector a representative from the engineering firm shall be present as arranged by the inspector.
4. Testing shall consist of air and/or exfiltration tests for sanitary sewer lines and air and/or vacuum tests for manholes. The Sanitary Engineering Department Inspector must be present to witness all testing of sanitary sewers.
5. Sanitary sewers are required to have a final inspection performed by the Allen County Sanitary Engineering Department Inspector and Wastewater Collection Superintendent with the contractor being present before approval of final plat will be given. The County must complete a video inspection of the system after completion of construction and testing before final approval may be given.
6. Kor-n-seal manhole connections shall be used when connecting into any existing manholes. The appropriate Kor-n-seal details shall be present on all construction drawings.
7. All sanitary sewer laterals shall be 6" in diameter and will be ran to the right-of-way and/or property line. The lateral pipe material shall be compatible with the main line material.
8. All laterals provided to the right-of-way and/or property line must be air tested at the same time as the main line.
9. Bonds or Letters of Credit will only be accepted by the Sanitary Engineering Department for sanitary sewer systems, which are "substantially complete" (See Definition). A Bond or Letter Credit will not be accepted for more than 25% of the total construction estimates.
10. As-Built drawings showing all sanitary sewer laterals shall be provided to the Sanitary Engineering Department before approval of the final plat may be given.
11. All newly installed sanitary manholes shall have a "No Flow In Flow" manhole dish (ASTM-D-1248) or an acceptable equivalent for prevention of Infiltration and Inflow.
12. All newly installed sanitary manholes shall be constructed with interior chimney seals (ASTM C-923) between dome and casting , and Infi-shield seal wraps for manhole joints.

Definition:

substantially complete: Any sanitary sewer system, which is capable of being tapped into and providing quality sanitary service.

APPENDIX B

Sanitary Engineering Department

General Details

Casting including frame and lid shall be heavy duty and together weigh at least 300 pounds. The lid shall be 23 3/4" in diameter and 1 1/2" thick at the outside edge. Casting and frame to be Neenah R-1668, East Jordan 1590 or equal. Provide Solid Lids with machined bearing surface between Lid and Frame in paved areas and where noted.

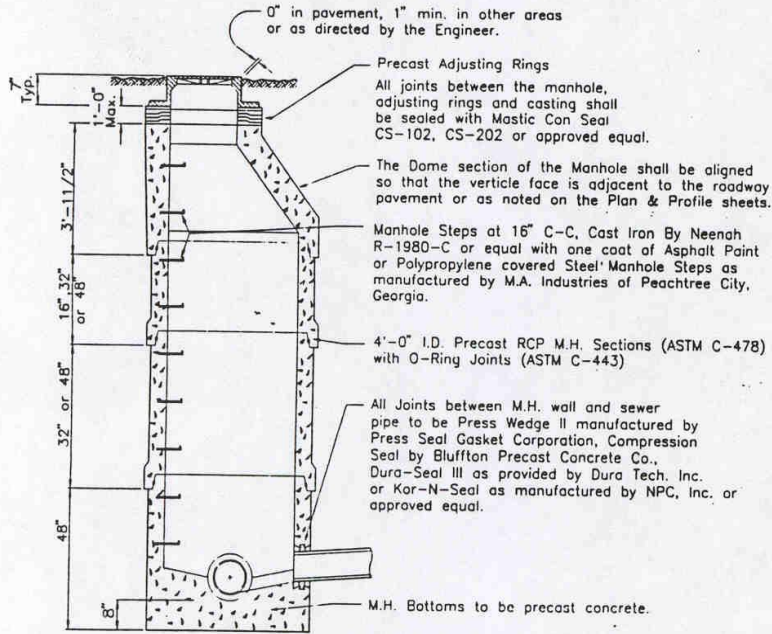

TYPE "A" MANHOLE

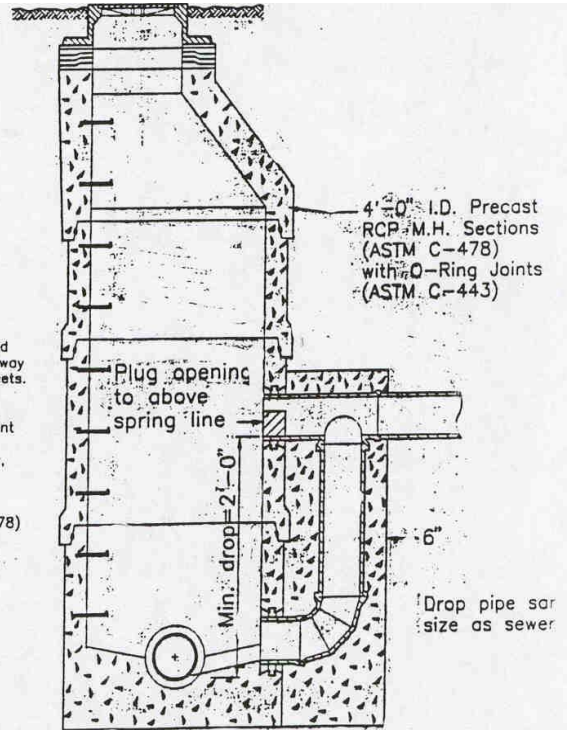

TYPE "B" MANHOLE

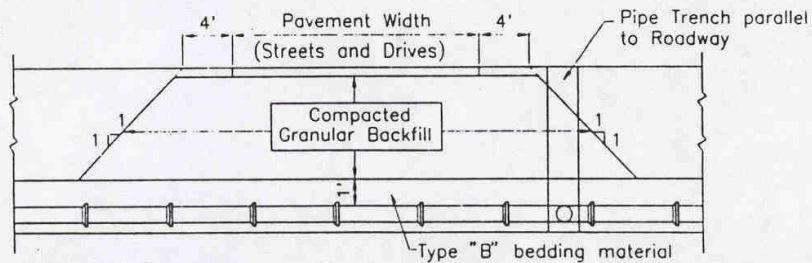

$$C.Y. = \frac{W \times L \times D}{27}$$

Where: W = I.D. Pipe + 2'

D = Depth from Subgrade of Pavement to 1' above Pipe Barrel

L = Pavement Width + B' + D or length of area filled with Item 912 + D

GRANULAR BACKFILL LIMITS

APPENDIX B (cont)

Sanitary Engineering Department

General Details

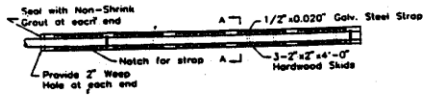

NOTE: Casing to be 4" larger in dia. than carrier pipe bell. Casing to be filled with grout after carrier pipe is installed. Carrier pipe bell shall not touch casing pipe.

BORING DETAILS

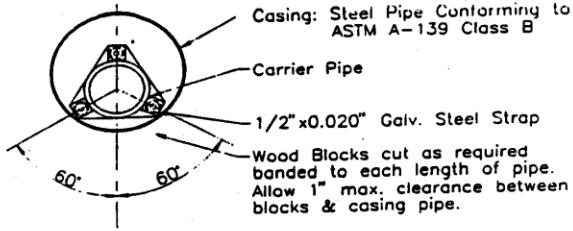

SECTION A-A

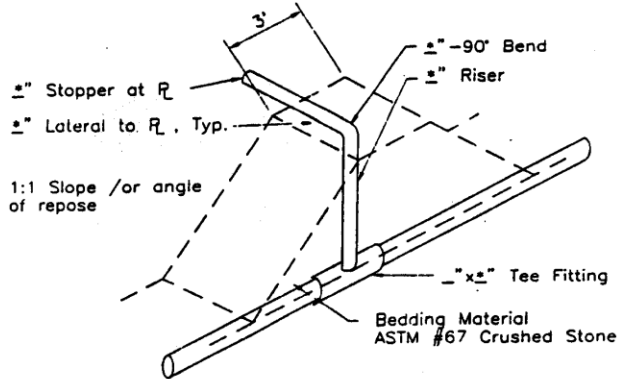

RISER DETAIL

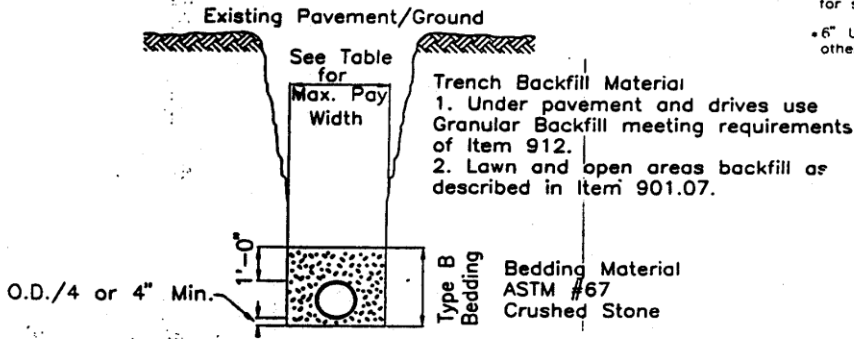

TYPICAL SEWER TRENCH

Pipe Size	6'-12"	15'-21"	24'-27"
Max. Pay Trench Width	36"	42"	48"
Max. Pay Pavement Width	6'-0"	6'-6"	7'-0"

MAXIMUM PAY WIDTH TABLE

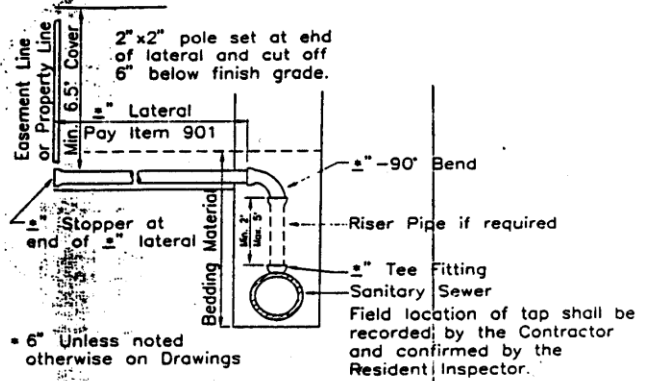

SEWER CONNECTION

For Mainline Sewers 12' Deep or Less Tee in Vertical Position

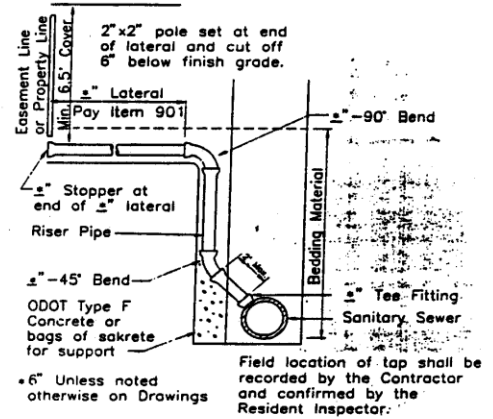

SEWER CONNECTION

For Mainline Sewers over 12' Deep Tee at 45° Angle

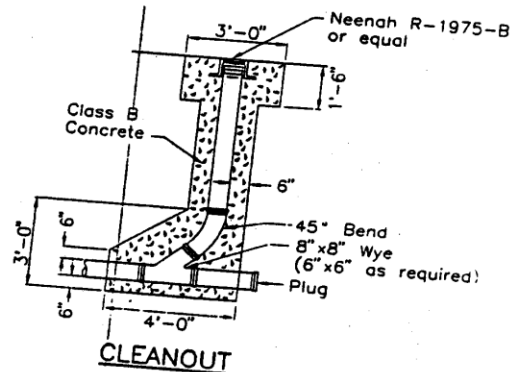

CLEANOUT

APPENDIX C
Procedures and Requirements:
Tap Connection to an Approved Sanitary Sewer System
Allen County, Ohio

When an approved sanitary sewer becomes available to your property, it is necessary to perform the following:

1. Obtain a permit or application to connect from the Allen County Sanitary Engineer's Office, 204 North Main Street, Suite 301, Lima, OH 45801, Telephone #: 228-3700, Ext. 8866. A yellow copy of the permit will be given at this time, and will be required to be on the job site at the time of lateral excavation. **No inspection will be conducted without this yellow copy of the permit.**
2. The property owner or contractor according to the specifications stated herein must do tapping of approved sanitary sewer system.
3. Call the Allen County Sanitary Engineer's Office for inspection of all work performed before backfilling is completed.
4. If a septic tank exists on the property, the following must be done:
 - a.) Disconnect building sewer from septic tank.
 - b.) Have the septic tank's contents removed by a licensed scavenger.
 - c.) Crack the bottom of tank, remove tank lid and fill the empty tank with a solid inert material (ex. earth or stone).
 - d.) Uncover building sewer to building drain for inspection of condition and material. At least two (2) joints shall be exposed.
 - e.) Plumbing waste lines and other drain lines within and outside the dwelling or public building shall be inspected for compliance with the following: roof down spout drains, footer drains, sump pumps discharging footer drain water, cistern over flow drains, and surface and sub-surface drainage lines are not allowed to be connected to the building sanitary drain or building sewer. Only water used within the building shall be discharged to the sanitary sewer. **NO INDUSTRIAL OR HAZARDOUS WASTE MATERIALS ARE ALLOWED IN OUR SANITARY SEWER SYSTEM AT ANY TIME.**
 - f.) If any questions arise, please contact the Public Health Department at (419) 228-4457 (Contact person: Mr. Bill Kelly).
1. The building sewer for a one (1), two (2), or three (3) family dwelling shall be at least four (4) inches nominal inside diameter. The building sewer for all commercial, industrial or public buildings shall be at least six (6) inches nominal inside diameter. The minimum slope shall be 1/8" per foot. The building sewer shall be connected to the building drain by using a flexible neoprene coupling with stainless steel clamps or a solid watertight connector.

APPENDIX C (cont)
Procedures and Requirements:
Tap Connection to an Approved Sanitary Sewer System
Allen County, Ohio

5. A building sewer shall be laid in undisturbed earth using premium joint pipe as listed below. "Clean-outs" shall be installed as follows:
 - a.) One (1) within ten (10) feet from your building.
 - b.) One (1) every one hundred (100) feet of length to the sanitary sewer, or at any change in direction greater than 45°.
 - c.) Types of acceptable pipe which can be used for laterals:
 - 1.) Vitrified Clay sewer pipe (V.C.P.) conforming to (ASTM-C-700).
 - 2.) Polyvinyl Chloride (PVC) meeting (ASTM-D-3034 SDR 35).
 - 3.) Plastic pipe meeting Schedule 40 pipe and National Sanitation Foundation (NSF). All ASTM numbers should refer to latest revision. When using Schedule 40 pipe, the bedding should be undisturbed virgin soil.
 - 4.) All building sewers less than Schedule 40 wall thickness shall be backfilled with #57 stone to 12 inches above the top of the pipe and 4" below and 6" on each side.
6. If there is a sanitary sewer manhole on the property or street right-of-way, it shall not be covered for any reason. Should you desire to raise the elevation of the ground, you must notify this office so that arrangements can be made to raise the opening. Should you fail to notify this office and cover the manhole, this office may take one of several actions:
 - a.) Remove the fill over the manhole.
 - b.) Raise the manhole and charge the contractor or the owner for any expense involved.
7. When it is necessary to tap a sanitary main, department personnel will drill the opening with two (2) sizes available which will accommodate a 4" or a 6" T-saddle which we will provide.
8. **When calling the Sanitary Engineering Department to make a tap, please call at least 24 hours in advance, and have the job site prepared with materials on hand prior to our arrival.**
9. **When calling for tap inspection from the Sanitary Engineering Department's Inspector, please call at least 24 hours in advance, and have the job site prepared for inspection prior to our arrival.**

Stephen M. Kayatin, P.E.

Sanitary Engineer

Revised 4/15/98

F:\DEPTFILE\ADMIN\tapconn.doc

APPENDIX D

Sanitary Engineering Department

Typical "As Built" Sheet

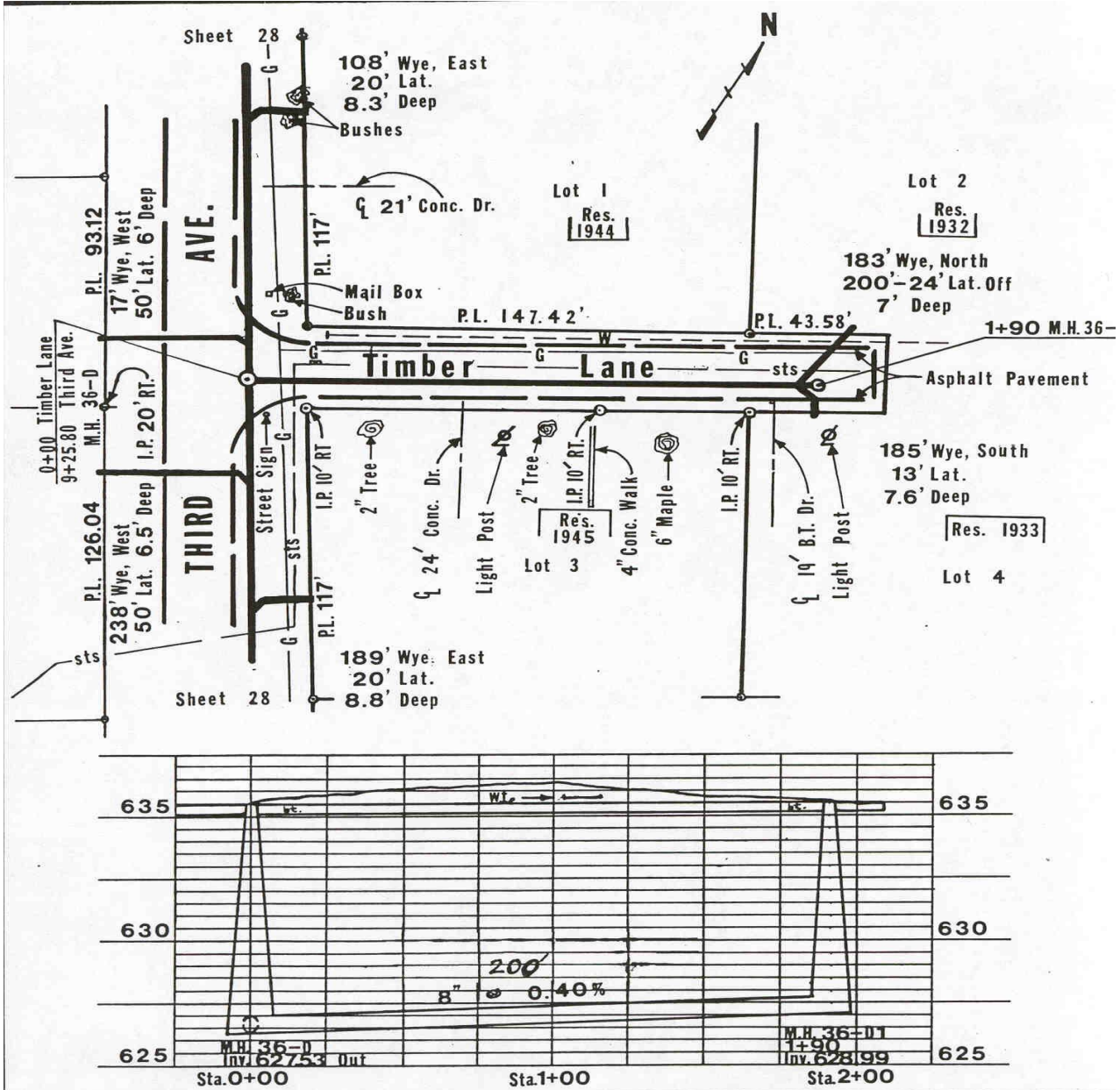

Rev. 78 by D.B.

Scale:
1"=5' Vert.
1"=50' Hor.

TYPICAL "AS BUILT" PLAN & PROFILE SHEET

Sanitary Engineering
Department

Approved _____

Date _____

Sanitary Engineer